

Sandwich Counters with Cold Pan

Sandwich Counter with Cold Pan (2°C to 4°C) facilitate refrigerated storage and quick dispensing of pizza toppings for faster preparation of sandwiches. In order to cater to the diversified demand of the clients, we offer cold pans in different sizes and designs.

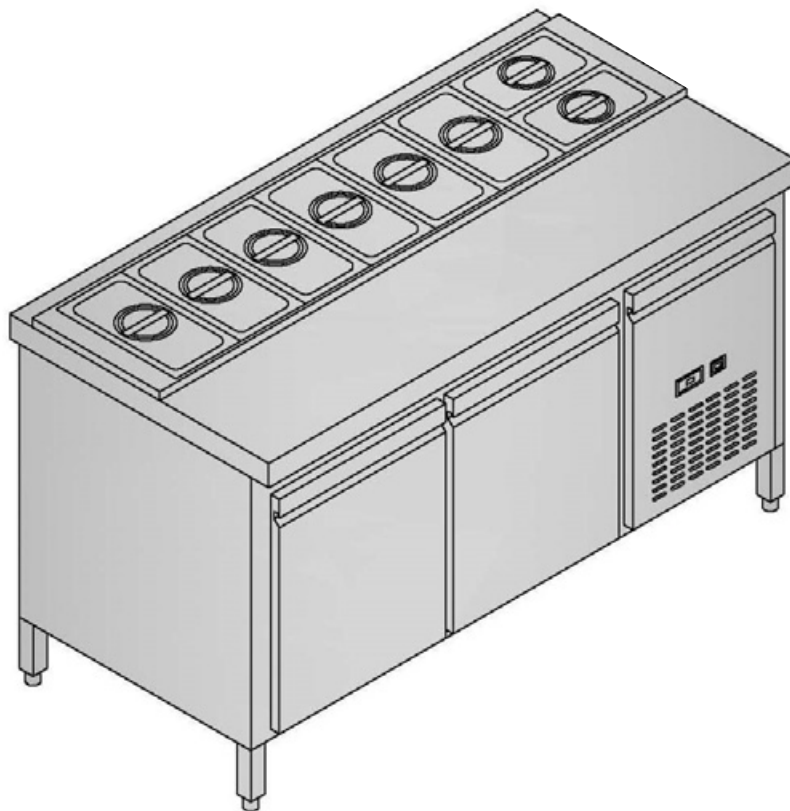

Model	Door	Overall Size w x d x h (mm)	Cold Pan (mm)	Capacity (Litres)	Electrical Rating (V / Ph / Kw)
CC 2 - SC	2	1220 x 700 x 850 +150	1040 x 305 x 155	298	230 / 1 / 0.58
CC 3 - SC	3	1690 x 700 x 850 +150	1570 x 305 x 155	460	230 / 1 / 0.63

FEATURES

- Forced draft cooling
- Self closing doors
- Automatic defrost, cycle
- Condensate heater
- 1 no. anti corrosive wire shelf of size GN1/1 per door
- Coved corners
- Lockable doors
- Designed to operate at up to 43°C ambient
- GN size cold pans 155mm deep

TECHNICAL SPECIFICATIONS

- R134a refrigerant
- Top in 18 swg SS sheet bent 50mm on sides
- Digital temperature controller
- Exterior in 430 grade SS Sheet
- Interior in 304 grade SS Sheet
- 60mm in-situ puf insulation
- Tecumseh / Emerson / Danfoss make refrigeration unit
- SS shelves in case of static cooling
- Glass shelves in case of forced draft cooling

OPTIONAL

- Stone top
- Castors
- Door heaters
- Static cooling
- Remote access to controller
- Cylinder locks instead of locking plate
- Extra shelves & ledges
- Hinged slanting lids
- Hinged lids with work top
- Glass sneeze guards

Sale / Registered Office: A-2, 2nd floor, Shopping Centre,
Naraina Industrial Area, Phase-II, New Delhi-110028
Ph.: +91-11-43157300, **Mob.:** 9810590040
Email: salesdesk@asterindia.com

aster
Food service equipment